

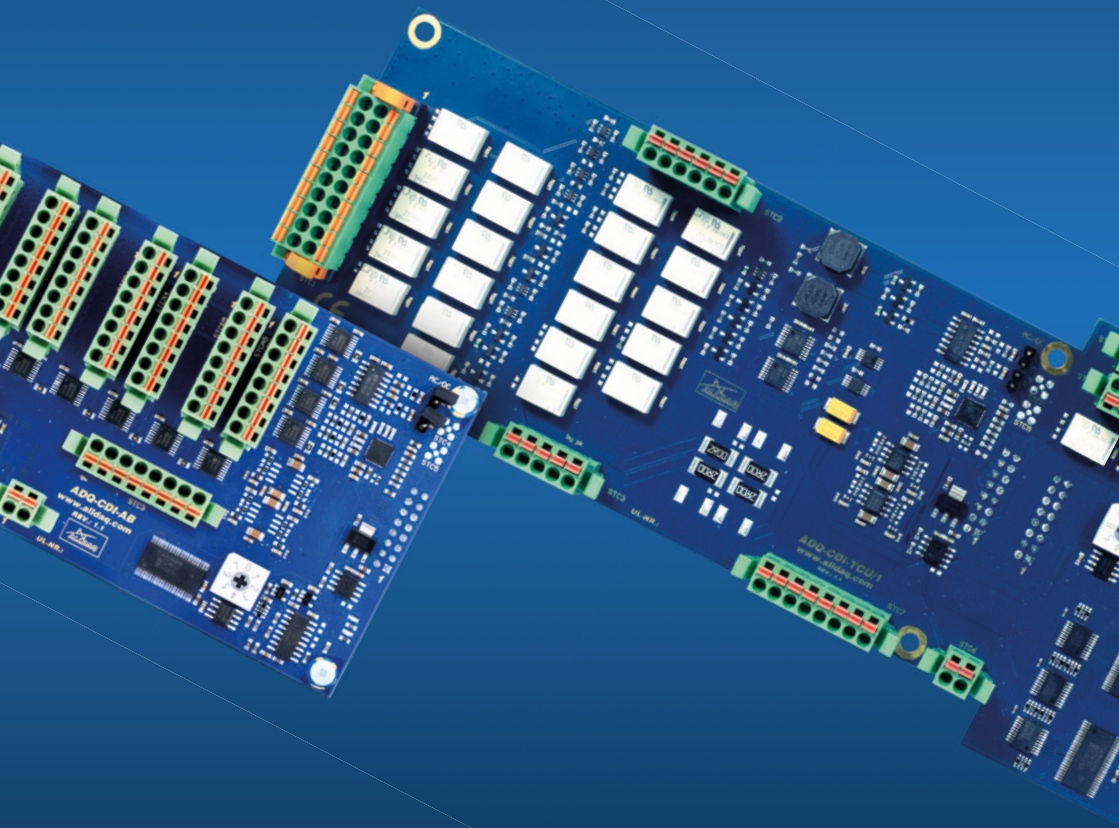

ADQ-HATs

Rev. 1.2 EN



Imprint

Manual ADQ-HATs
Rev. 1.2 DE
Date: 29.10.2024

Manufacturer and support

ALLNET® and ALLDAQ® are registered trademarks of ALLNET® GmbH Computersysteme. For questions, problems and product information, please contact the manufacturer directly:

ALLNET® GmbH Computersysteme

Division ALLDAQ
Maistrasse 2
D-82110 Germering

Support

E-Mail: support@alldaq.com
Phone: +49 (0)89 894 222 – 474
Fax: +49 (0)89 894 222 – 33
Web: www.alldaq.com/support

© Copyright 2021 ALLNET GmbH Computersysteme. All rights reserved.

All information contained in this manual has been compiled with the utmost care and to the best of our knowledge. Nevertheless, errors cannot be completely ruled out. Specifications and contents of this manual are subject to change without notice.

We are always grateful for notification of any errors.

Mentioned trademarks are registered trademarks of the respective companies.

Contents

1.	Introduction	7
1.1	Scope of delivery	7
1.2	Safety instructions	7
1.3	Installation and mounting location	8
1.4	Plug-on boards (HATs)	8
1.4.1	HAT1/HAT3	8
1.4.2	HAT2	8
2.	Short description ADQ-CDI-AB	9
2.1	Overview of the ADQ-CDI-AB system	10
2.2	Analog/digital inputs and outputs	10
2.3	Analog inputs/outputs	11
2.4	Power supply	13
2.5	Control system	13
2.6	Rotary switch	13
2.7	Pin assignments	14
2.7.1	Position of the connectors/jumpers	14
2.8	Overview of connector types	15
2.8.1	Würth type	15
2.8.2	Type male connector	15
2.9	Pin assignment	16
2.10	Specifications ADQ-CDI-AB	22
3.	Short description ADQ-CDI-TCU/1	27
3.1	Overview of the ADQ-CDI-TCU/1 system	28
3.1.1	Connectors (inputs/outputs)	28
3.1.2	Switching matrix	29
3.1.3	Measuring unit	30
3.1.3	Calibration of the ADQ-CDI-TCU/1 LC	30
4.	Short description ADQ-CDI-TCU/1 LC	31
4.1	Overview of the ADQ-CDI-TCU/1 LC system	32
4.1.1	Connectors (inputs/outputs)	32
4.1.2	Switching matrix	33

4.1.3	Measuring unit	34
4.2	Calibration of the ADQ-CDI-TCU/1 LC	34
5.	Control unit ADQ-CDI-TCU/1 & -TCU/1 LC	35
5.1	Control system	35
5.2	Rotary switch	35
6.	Pin assignments ADQ-CDI-TCU/1 & -TCU/1 LC	37
6.1	Position of the connectors/jumpers	37
6.2	Overview of connector types	38
6.2.1	Würth/Phoenix type	38
6.2.2	Type male connector	38
6.3	Pin assignment	39
7.	Specifications ADQ-CDI-TCU/1	45
8.	Specifications ADQ-CDI-TCU/1 LC	49
9.	Appendix	51
9.1	Manufacturer and support	51
9.2	Important notes	51
9.2.1	Packaging Ordinance	51
9.2.2	Recycling notice and RoHS conformity	52
9.2.3	CE marking	52
9.2.4	Warranty	52

1. Introduction

Please check the packaging and contents for damage and completeness before commissioning. Should any defects occur, please inform us immediately..

- Does the packaging indicate that something was damaged during transportation?
- Are there any signs of use on the device?

Under no circumstances should you operate the appliance if it is damaged. If in doubt, please contact our technical customer service.

Please read this manual carefully before installing and programming the device!

1.1 Scope of delivery

- ALLDAQ HATs

1.2 Safety instructions



Please note the following instructions:

- **The ADQ-HATs may only be operated in conjunction with the ADQ-CDI-BB**
- Avoid touching cables and connectors
- Never expose the device to direct sunlight during operation.
- Never operate the device near heat sources.
- Protect the device from moisture, dust, liquids and vapors.
- Do not use the device in damp rooms or in potentially explosive atmospheres.
- Repairs may only be carried out by trained, authorized personnel.



- Please observe the installation regulations and all relevant standards (including VDE standards) when commissioning the device, especially when operating with voltages greater than 42 V.
- We recommend that unused inputs are always connected to the corresponding reference ground in order to avoid crosstalk between the input channels.



- Ensure that no static discharge can occur via the device when handling the card. Follow the standard ESD protection measures.
- Never connect the devices to live parts, especially not to mains voltage.
- Precautionary measures to avoid unforeseeable misuse must be taken by the user.

ALLNET® GmbH Computersysteme accepts no liability for damage resulting from improper use.

1.3 Installation and mounting location

The module is intended for installation in measuring and test systems by qualified specialist personnel. The relevant installation regulations and standards must be observed.

The module may only be used in dry rooms. Ensure sufficient heat dissipation. Ensure that the connection cables are securely seated. The installation must be carried out in such a way that the cables are not under tension, as otherwise they could come loose.

1.4 Plug-on boards (HATs)

Die ADQ-CDI-BB bietet mehrere Möglichkeiten zur Erweiterung. Unter anderem stehen Steckplätze für Erweiterungsplatinen (HATs) direkt auf der Baugruppe zur Verfügung. (weitere Infos siehe Handbuch ADQ-CDI-BB)

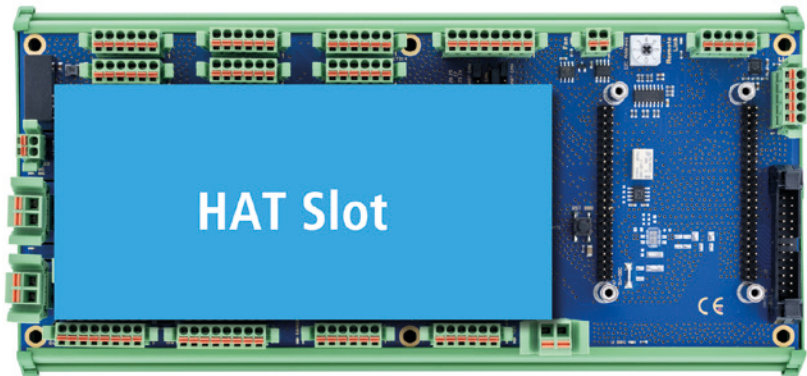

Figure 1: Position of expansion boards (HATs)

1.4.1 HAT1/HAT3

The ADQ-CDI-BB offers a slot for the HAT1/HAT3. In addition to the power supply voltages, 5VDC and 12VDC, other signals such as I2C, I2S, etc. are available depending on the HAT type. are available. (for further information see ADQ-CDI-BB manual)

1.4.2 HAT2

There is a connector for a simple HAT. The input voltage (U_{IN}), 5VDC and 12VDC and the I2C system bus are available at the connector provided for this purpose.

2. Short description ADQ-CDI-AB

The ADQ-CDI-AB (AB-Audio Board) extends the function or measurement tasks of the ADQ-CDI-BB. With this plug-on board (HAT) and an SBC (Single Board Computer) on the ADQ-CDI-BB, the analog inputs/outputs can be switched or measured via the I²S.

Features:

- 40 analog differential voltage inputs ± 10 VDC peak
- 4 analog single ended outputs 0.6VDC peak
- 4 analog single ended inputs 10VDC peak (on request)
- AUDIO-CODEC with I²S interface
- Pluggable on the ADQ-CDI-BB
- Controllable via the ADQ-CDI-BB (I²C)
- 100% control only with SBC (I²C, I²S)
- Power supply via ADQ-CDI-BB

Note: The brief description above refers to hardware versions Rev. 1.0/1.

2.1 Overview of the ADQ-CDI-AB system

2.2 Analog/digital inputs and outputs

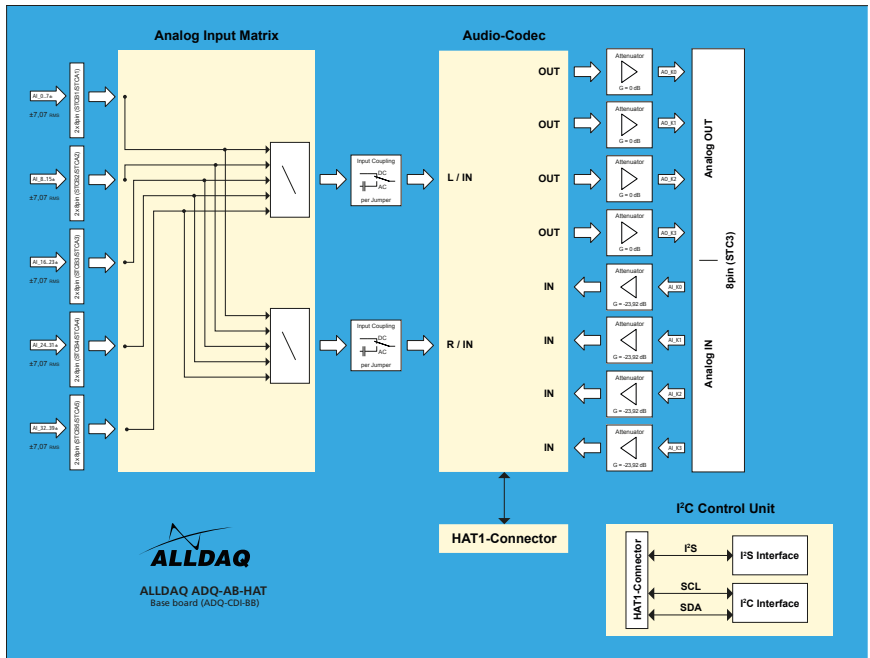

Figure 2: Block diagram of digital inputs and outputs

2.3 Analog inputs/outputs

There are 40 analog differential voltage inputs and 4 analog single-ended inputs/outputs available. Further technical information on the inputs and outputs can be found in the specifications.

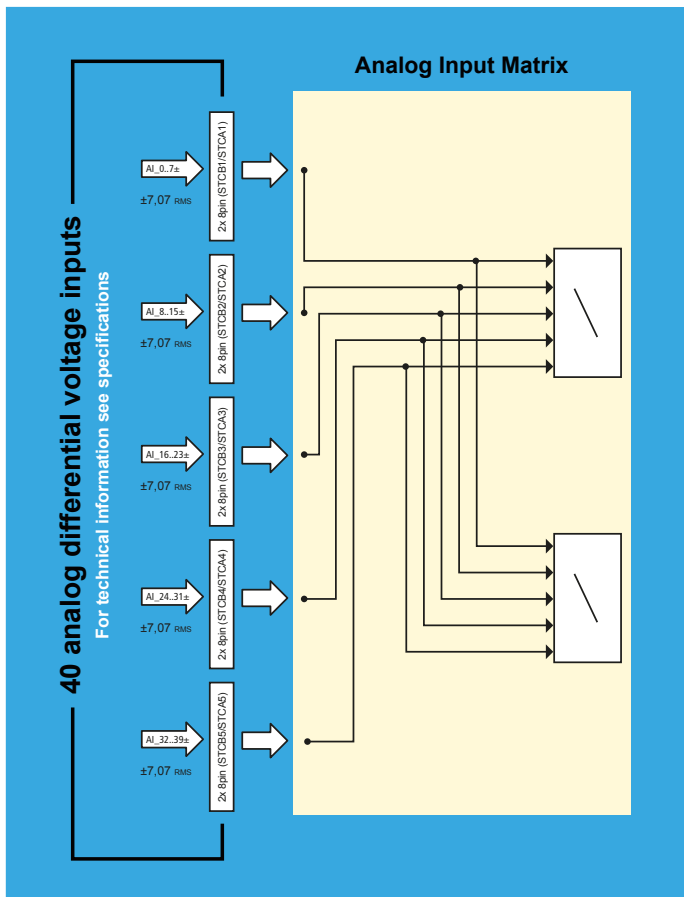

Figure 3: Block diagram 40 analog differential inputs

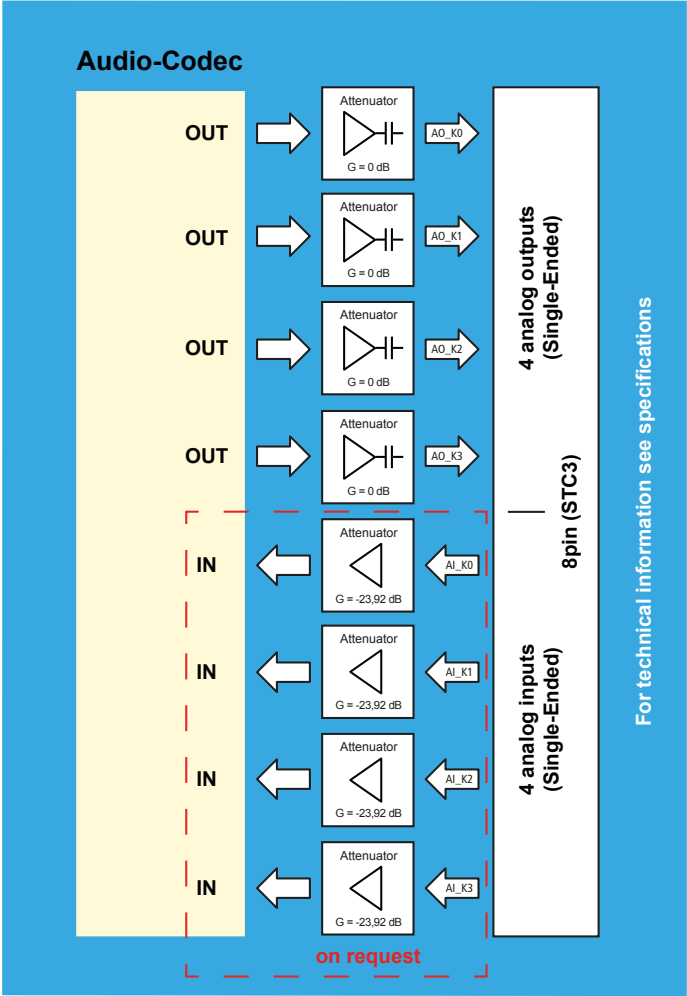

Figure 4: Block diagram 4 analog inputs/outputs

2.4 Power supply

The complete module is supplied via the ADQ-CDI-BB. (5VDC, 12VDC)

2.5 Control system

The single-board computer is always used to fully control the ADQ-CDI-AB (default).

In addition, the HAT can be controlled via the ADQ-CDI-BB using the STB18 ADQ-Link connector (service mode) and the I2C-Board Control Center (ALLDAQ driver). The full range of functions of the ADQ-CDI-AB is not available here.

2.6 Rotary switch

Use the rotary switch to determine the main address of the ADQ-CDI-AB module. The address may only occur once on an ADQ link or I2C bus. This also applies to other peripherals. All ADQ-Link products have an adjustable rotary switch.

Position	Address (7 bit)
0	0x70
1	0x71
2	0x72
3	0x73
4	0x74
5	0x75
6	0x76
7	reserved*

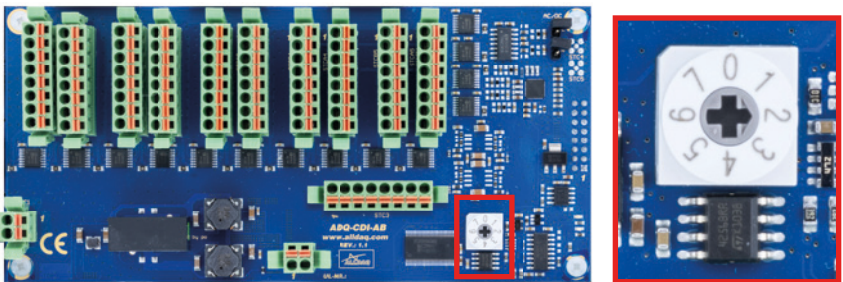

Figure 5: Rotary switch

2.7 Pin assignments

2.7.1 Position of the connectors/jumpers

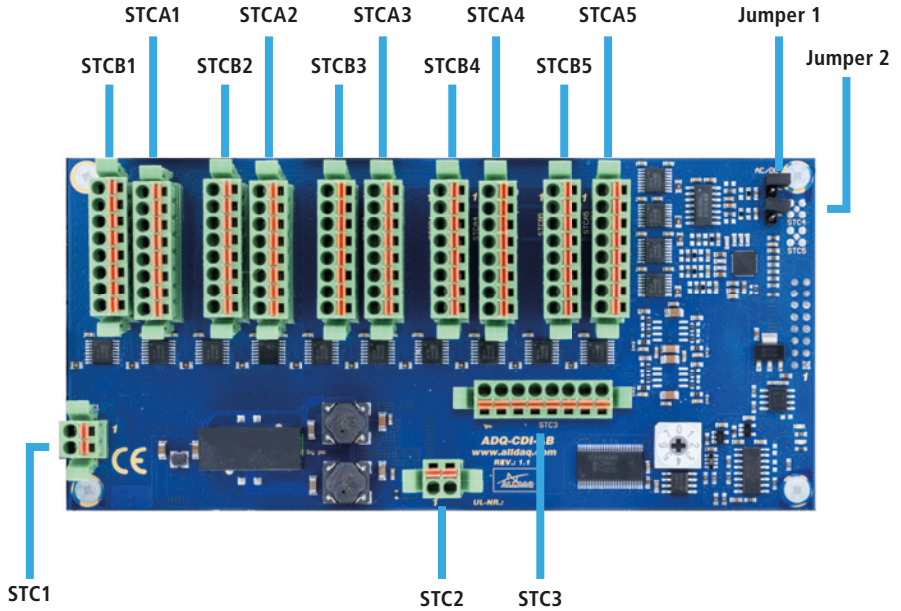

Figure 6: ADQ-CDI-AB-HAT with connector position

2.8 Overview of connector types

2.8.1 Würth type

Connectors from the Therma/Würth 69130513.... series with different numbers of poles are used.

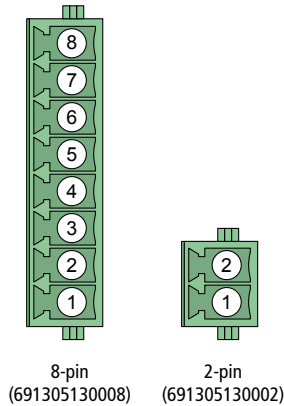

Figure 7: Würth baseboard type WR-TBL 3051 (top view)

2.8.2 Type male connector

A 16-pin socket connector is used for the connection between the baseboard (ADQ-CDI-BB) and the HAT plug-on modules (ADQ-CDI-Ab-HAT) (pitch: 2.54 mm).

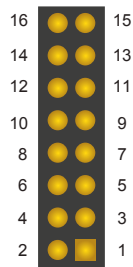

Figure 8: Socket connector, 2.54mm (top view)

2.9 Pin assignment

STC1/STC2

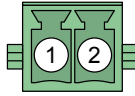

Figure 9: Würth 691305130002

Pin	Assignment	Description
1	AGND	Analog GND
2	AGND	Analog GND

Table 1: Pin assignment STC1/STC2

STCA1 INPUT K0 - K7

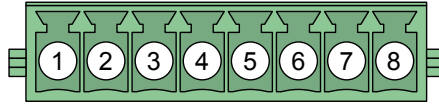

Table 2: Würth 691305130008

Pin	Designation	Description
1	+K7	pos. diff. Input
2	+K6	pos. diff. Input
3	+K5	pos. diff. Input
4	+K4	pos. diff. Input
5	+K3	pos. diff. Input
6	+K2	pos. diff. Input
7	+K1	pos. diff. Input
8	+K0	pos. diff. Input

Table 3: Pin assignment STCA1

STCB1 INPUT K0 - K7

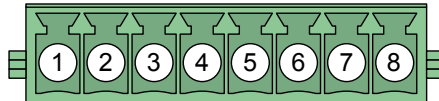

Figure 10: Würth 691305130008

Pin	Designation	Description
1	-K7	neg. diff. Input
2	-K6	neg. diff. Input
3	-K5	neg. diff. Input
4	-K4	neg. diff. Input
5	-K3	neg. diff. Input
6	-K2	neg. diff. Input
7	-K1	neg. diff. Input
8	-K0	neg. diff. Input

Table 4: Pin assignment STCB1STCA1 INPUT K0 - K7

STCA2 INPUT K8 - K15

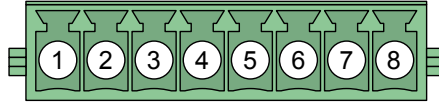

Figure 11: Würth 691305130008

Pin	Designation	Description
1	+K15	pos. diff. Input
2	+K14	pos. diff. Input
3	+K13	pos. diff. Input
4	+K12	pos. diff. Input
5	+K11	pos. diff. Input
6	+K10	pos. diff. Input
7	+K9	pos. diff. Input
8	+K8	pos. diff. Input

Table 5: Pin assignment STCA2

STCB2 INPUT K8 - K15

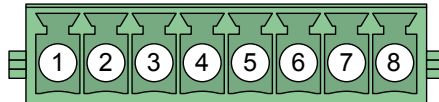

Figure 12: Würth 691305130008

Pin	Designation	Description
1	-K15	neg. diff. Input
2	-K14	neg. diff. Input
3	-K13	neg. diff. Input
4	-K12	neg. diff. Input
5	-K11	neg. diff. Input
6	-K10	neg. diff. Input
7	-K9	neg. diff. Input
8	-K8	neg. diff. Input

Tabelle 6: Pin assignment STCB2

STCA3 INPUT K16 - K23

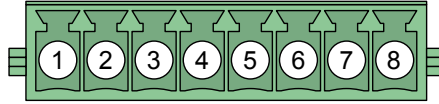

Figure 13: Würth 691305130008

Pin	Designation	Description
1	+K23	pos. diff. Input
2	+K22	pos. diff. Input
3	+K21	pos. diff. Input
4	+K20	pos. diff. Input
5	+K19	pos. diff. Input
6	+K18	pos. diff. Input
7	+K17	pos. diff. Input
8	+K16	pos. diff. Input

Table 7: Pin assignment STCA3

STCB3 INPUT K16 - K23

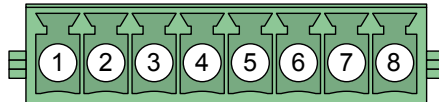

Figure 14: Würth 691305130008

Pin	Designation	Description
1	-K23	neg. diff. Input
2	-K22	neg. diff. Input
3	-K21	neg. diff. Input
4	-K20	neg. diff. Input
5	-K19	neg. diff. Input
6	-K18	neg. diff. Input
7	-K17	neg. diff. Input
8	-K16	neg. diff. Input

Table 8: Pin assignment STCB3

STCA4 INPUT K24 - K31

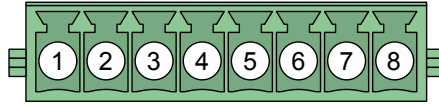

Figure 15: Würth 691305130008

Pin	Designation	Description
1	+K31	pos. diff. Input
2	+K30	pos. diff. Input
3	+K29	pos. diff. Input
4	+K28	pos. diff. Input
5	+K27	pos. diff. Input
6	+K26	pos. diff. Input
7	+K25	pos. diff. Input
8	+K24	pos. diff. Input

Table 9: Pin assignment STCA4

STCB4 INPUT K24 - K31

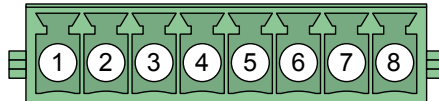

Figure 16: Würth 691305130008

Pin	Designation	Description
1	-K31	neg. diff. Input
2	-K30	neg. diff. Input
3	-K29	neg. diff. Input
4	-K28	neg. diff. Input
5	-K27	neg. diff. Input
6	-K26	neg. diff. Input
7	-K25	neg. diff. Input
8	-K24	neg. diff. Input

Table 10: Pin assignment STCB4

STCA5 INPUT K32 - K39

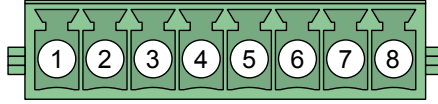

Figure 17: Würth 691305130008

Pin	Designation	Description
1	+K39	pos. diff. Input
2	+K38	pos. diff. Input
3	+K37	pos. diff. Input
4	+K36	pos. diff. Input
5	+K35	pos. diff. Input
6	+K34	pos. diff. Input
7	+K33	pos. diff. Input
8	+K32	pos. diff. Input

Table 11: Pin assignment STCA5

STCB5 INPUT K32 - K39

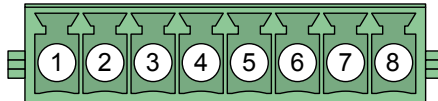

Figure 18: Würth 691305130008

Pin	Designation	Description
1	-K39	neg. diff. Input
2	-K38	neg. diff. Input
3	-K37	neg. diff. Input
4	-K36	neg. diff. Input
5	-K35	neg. diff. Input
6	-K34	neg. diff. Input
7	-K33	neg. diff. Input
8	-K32	neg. diff. Input

Table 12: Pin assignment STCB5

STC3 analog INPUT/OUTPUT

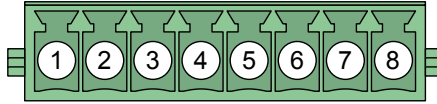

Figure 19: Würth 691305130008

Pin	Designation	Description
1	IN2_L	analog INPUT (Single-Ended)
2	IN2_R	analog INPUT (Single-Ended)
3	IN3_L	analog INPUT (Single-Ended)
4	IN3_R	analog INPUT (Single-Ended)
5	LOL	analog OUTPUT (Single-Ended)
6	LOR	analog OUTPUT (Single-Ended)
7	HPL	analog OUTPUT (Single-Ended)
8	HPR	analog OUTPUT (Single-Ended)

Table 13: Pin assignment STC3

2.10 Specifications ADQ-CDI-AB

Conditions TA = 25°C unless otherwise specified; warm-up time: 30 minutes.

Overall

Element	Condition	Specification
Control and signal processing	recommended	ADQ-CDI-AB-HAT for analog input/output, as well as control via I2C- and I2S-Bus/Beagle Bone Black
Supply		Supply via ADQ-CDI-BB
Temperature range	Operating	0..60 °C (Standard)
Air humidity	Operating	20%..55% (non-condensing)
Dimensions (W x D x H)	ADQ-CDI-AB	160 x 75 x 30 mm Clip-on HAT
Manufacturer warranty		36 months

Diff. analog inputs ADQ-CDI-AB

Element	Condition	Specification
Channels		40 AC differential inputs 10V peak
Range	CODEC	50 Hz to 20 KHz (see TLV320AIC3204 data sheet)
Sampling rate	CODEC	48 KHz/96 KHz/192 KHz (see TLV320AIC3204 data sheet)
Resolution	CODEC	16 bit (see TLV320AIC3204 data sheet)
Overall accuracy	±10V	0,1%FS
Input impedance	1kHz Sinus	2K ₁
Input capacity		68nF ₁

(1) Reactance XC (frequency-dependent)

Single-ended analog inputs ADQ-CDI-AB (on request)

Element	Condition	Specification
Channels		4 single-ended analog inputs (10V peak)
Range	CODEC	50 Hz to 20 KHz (see TLV320AIC3204 data sheet)
Sampling rate	CODEC	48 KHz/96 KHz/192 KHz (see TLV320AIC3204 data sheet)
Resolution	CODEC	16 bit (see TLV320AIC3204 data sheet)
Overall accuracy		TBD
Input impedance		10K Ω 0,47 μ F

Single-ended analog outputs ADQ-CDI-AB

Element	Condition	Specification
Channels		4 single-ended analog outputs (0.6V peak output range)
Range	CODEC	50 Hz to 20 KHz (see TLV320AIC3204 data sheet)
Output rate	CODEC	48 KHz/96 KHz/192 KHz (see TLV320AIC3204 data sheet)
Resolution	CODEC	16 Bit
Overall accuracy		
LOL/LOR	0V-0,5V	0,1%FS
HPL/HPR	0V-0,5V	TBD %FS
Max. Ausgangsstrom pro Kanal	Bis 85 °C	25 mA Short-circuit current 55 mA
Ausgangsimpedanz	1kHz Sinus	0,47 μF_1 (XC=338 Ω) (siehe Blockschaltbild Seite 12)

(1) Blindwiderstand XC (frequenzabhängig)

3. Short description ADQ-CDI-TCU/1

The ADQ-CDI-TCU/1 extends the function or measurement tasks of the ADQ-CDI-BB. With this plug-on board (HAT) and an SBC (Single Board Computer) on the ADQ-CDI-BB, the analog inputs/outputs can be switched or measured via the I²S.

Features:

- 4 analog single ended outputs 0.6VDC peak
- 4 analog single ended inputs 10VDC peak (on request)
- AUDIO-CODEC with I²S interface
- Pluggable on the ADQ-CDI-BB
- Controllable via the ADQ-CDI-BB (I²C)
- 100% control only with SBC (I²C, I²S)
- Power supply via ADQ-CDI-BB

Note: The above brief description refers to hardware versions Rev. 1.1/1.2

3.1 Overview of the ADQ-CDI-TCU/1 system

3.1.1 Connectors (inputs/outputs)

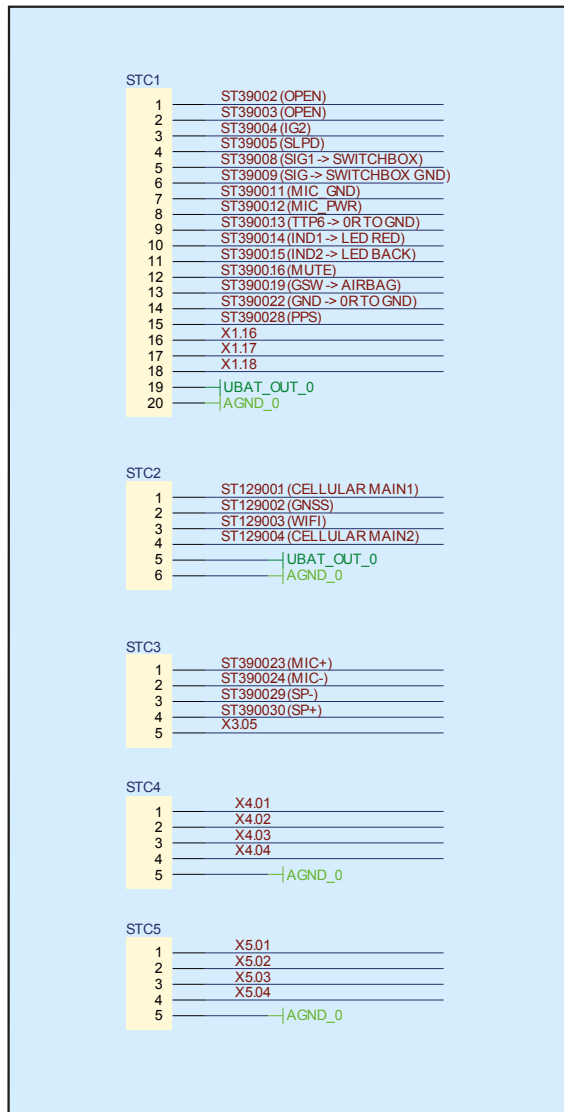

Figure 20: Block diagram connector ADQ-CDI-TCU/1

3.1.2 Switching matrix

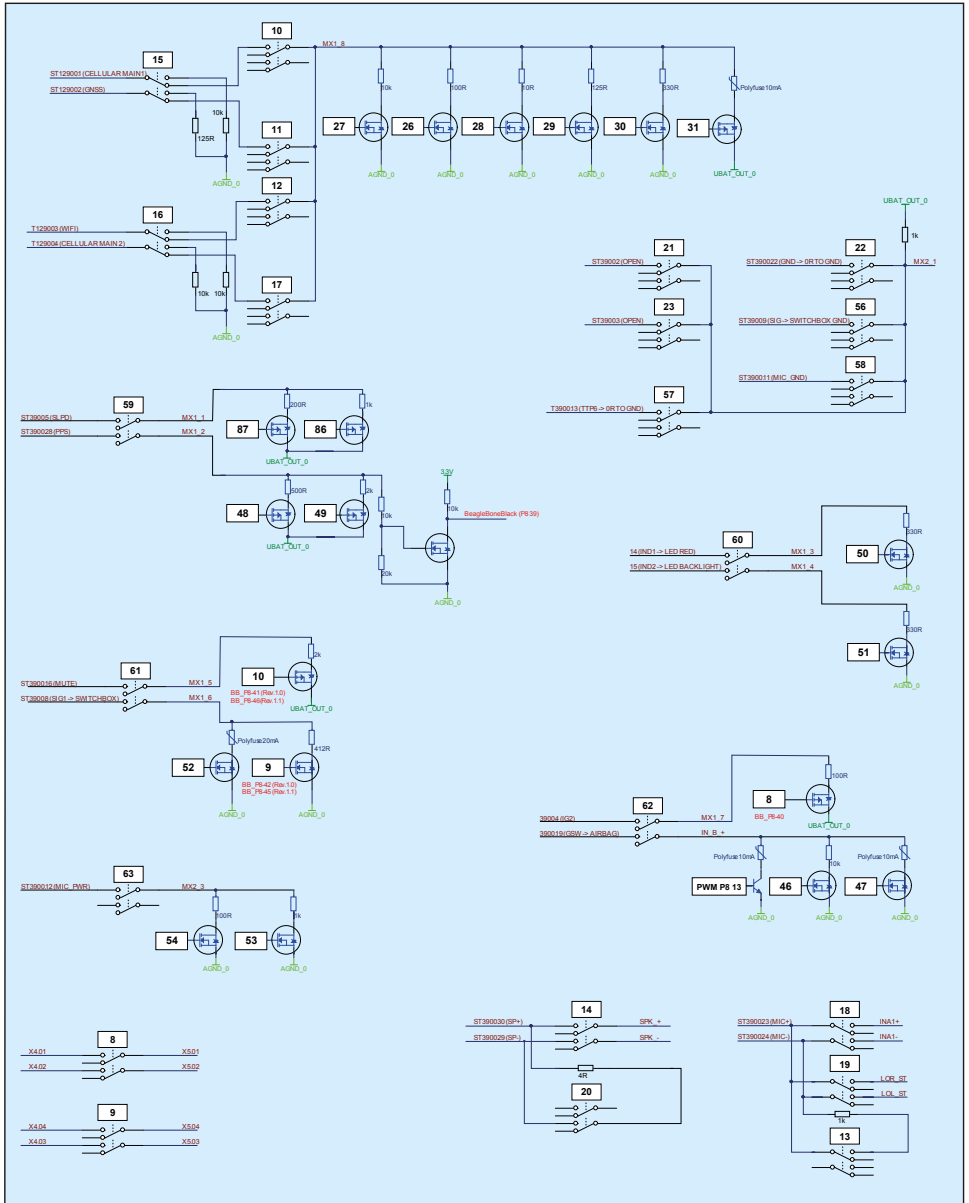

Figure 21: Block diagram of switching matrix ADQ-CDI-TCU/1

3.1.3 Measuring unit



Abb. 22: Blockschaubild Messeinheit ADQ-CDI-TCU/1

3.2 Calibration of the ADQ-CDI-TCU/1 LC

Text will follow soon.

4. Short description ADQ-CDI-TCU/1 LC

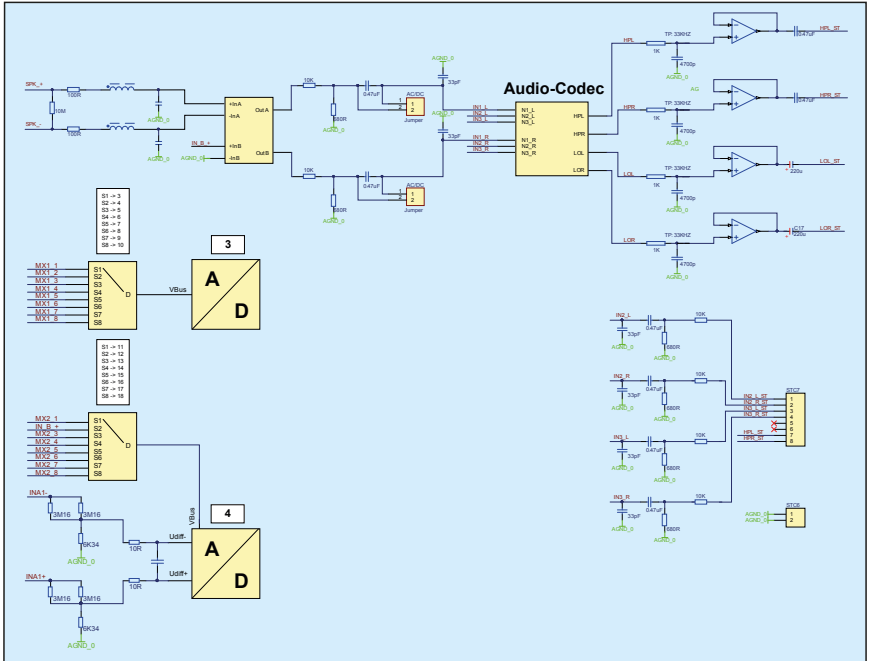
The ADQ-CDI-TCU/1 LC extends the function or measurement tasks of the ADQ-CDI-BB. With this plug-on board (HAT) and an SBC (Single Board Computer) on the ADQ-CDI-BB, the analog inputs/outputs can be switched or measured via the I²S.

Features:

- 2 analog single ended outputs 0.6VDC peak
- 4 analog single ended inputs 10VDC peak (on request)
- AUDIO-CODEC with I²S interface
- Pluggable on the ADQ-CDI-BB
- 100% control only with SBC (I²C, I²S)

Note: The above brief description refers to hardware versions Rev. 1.1/1.2

4.1 Overview of the ADQ-CDI-TCU/1 LC system

4.1.1 Connectors (inputs/outputs)

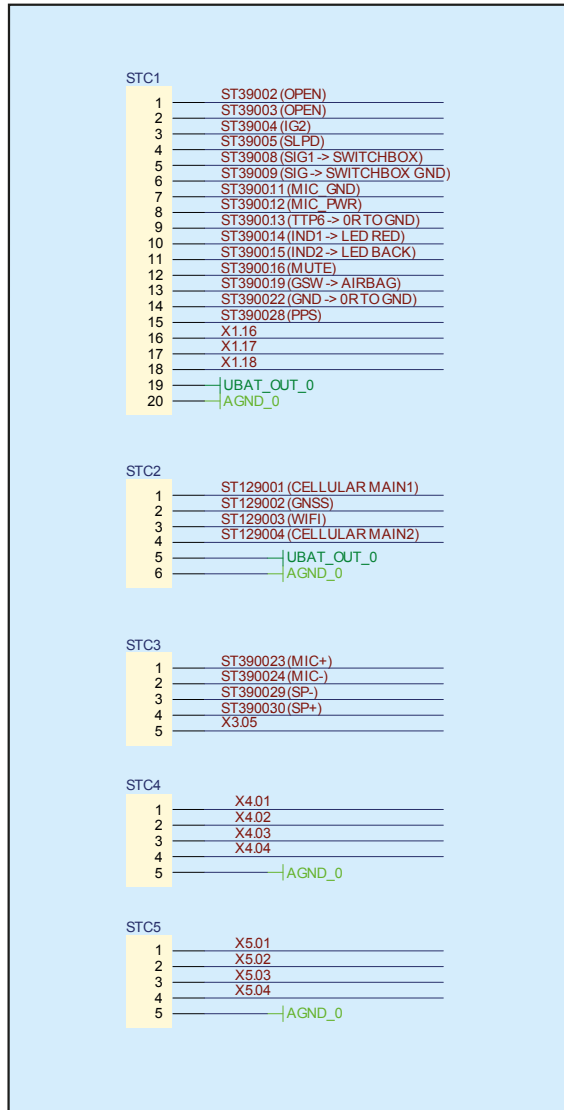

Figure 23: Block diagram connector ADQ-CDI-TCU/1 LC

4.1.2 Switching matrix

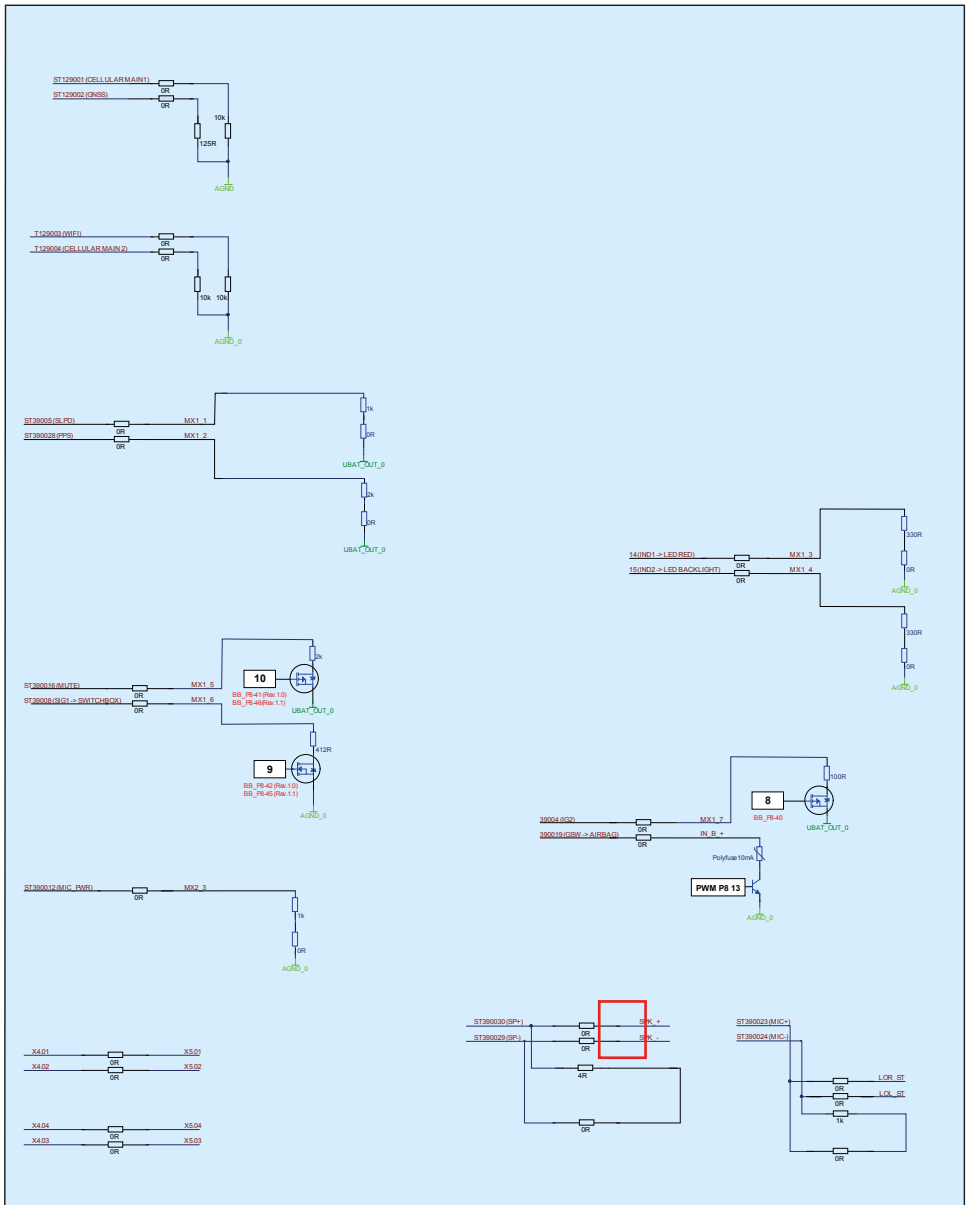

Figure 24: Block diagram of switching matrix ADQ-CDI-TCU/1 LC

4.1.3 Switching matrix

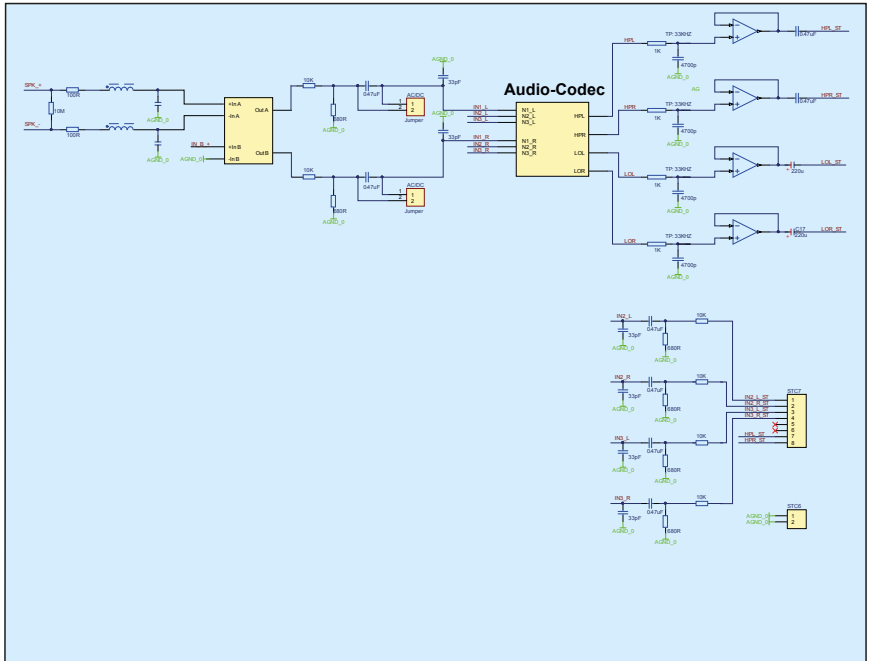

Figure 25: Block diagram of measuring unit ADQ-CDI-TCU/1 LC

4.2 Calibration of the ADQ-CDI-TCU/1 LC

Text will follow soon.

5. Control unit ADQ-CDI-TCU/1 & -TCU/1 LC

5.1 Control system

The single-board computer is always used for full control of the ADQ-CDI-TCU/1 & ADQ-CDI-TCU/1 LC (default).

In addition, the HAT can be controlled via the ADQ-CDI-BB using the STB18 ADQ-Link connector (service mode) and the I2C-Board Control Center (ALLDAQ driver). The full range of functions of the ADQ-CDI-TCU/1 & ADQ-CDI-TCU/1 LC is not available here.

5.2 Rotary switch

Use the rotary switch to determine the main address of the ADQ-CDI-TCU/1 & ADQ-CDI-TCU/1 LC module. The address may only occur once on an ADQ-Link or I2C bus. This also applies to other peripherals. All ADQ-Link products have an adjustable rotary switch.

Position	Adress (7 bit)
0	0x70
1	0x71
2	0x72
3	0x73
4	0x74
5	0x75
6	0x76
7	reserved*

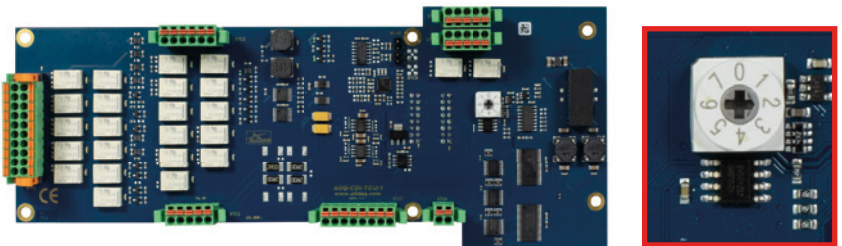

Figure 26: Rotary switch ADQ-CDI-TCU/1 & ADQ-CDI-TCU/1 LC

6. Pin assignments ADQ-CDI-TCU/1 & -TCU/1 LC

6.1 Position of the connectors/jumpers

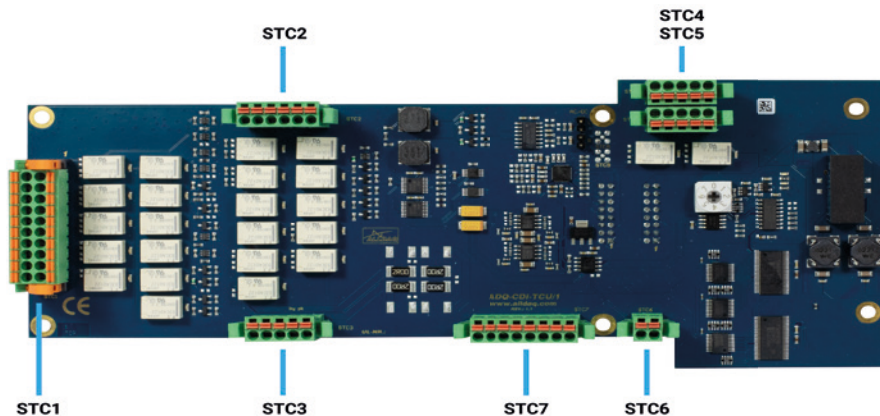

Figure 27: ADQ-CDI-TCU/1 & ADQ-CDI-TCU/1 LC with connector position

6.2 Overview of connector types

6.2.1 Würth/Phoenix type

Würth/Phoenix connectors with different numbers of poles are used.

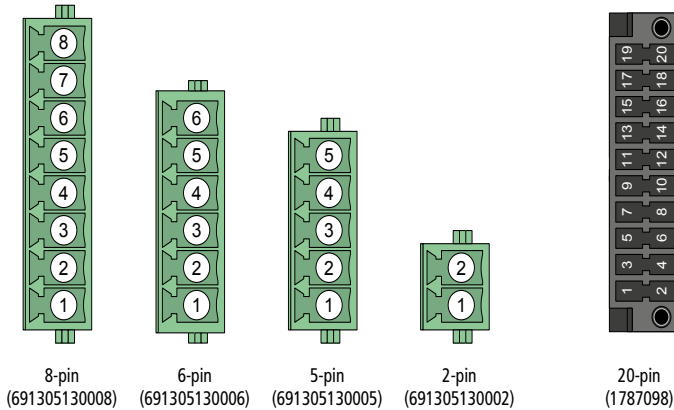

Figure 28: Würth/Phoenix base rail (top view)

6.2.2 Type male connector

Two 16-pin socket connectors are used for the connection between the baseboard (ADQ-CDI-BB) and the HAT plug-on modules (ADQ-CDI-TCU-HAT) (pitch: 2.54 mm).

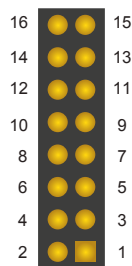

Figure 29: Socket connector, 2.54mm (top view)

6.3 Pin assignment

STC6

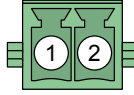

Figure 30: Würth 691305130002

Pin	Assignment	Description
1	AGND	Analog GND
2	AGND	Analog GND

Table 14: Pin assignment STC6

STC7 analog INPUT/OUTPUT

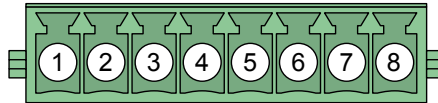

Figure 31: Würth 691305130008

Pin	Designation	Description
1	IN2_L	analog INPUT (Single-Ended)
2	IN2_R	analog INPUT (Single-Ended)
3	IN3_L	analog INPUT (Single-Ended)
4	IN3_R	analog INPUT (Single-Ended)
5	NC	not occupied
6	NC	not occupied
7	HPL	analog OUTPUT (Single-Ended)
8	HPR	analog OUTPUT (Single-Ended)

Table 15: Pin assignment STC7

STC4

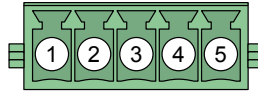

Figure 32: Würth 691305130005

Pin	Designation	Description
1	X4.01	Relay switching cables
2	X4.02	Relay switching cables
3	X4.03	Relay switching cables
4	X4.04	Relay switching cables
5	AGND_0	Analog GND

Table 16: Pin assignment STC4

STC5

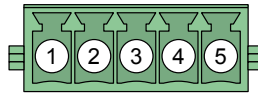

Figure 33: Würth 691305130005

Pin	Designation	Description
1	X5.01	Relay switching cables
2	X5.02	Relay switching cables
3	X5.03	Relay switching cables
4	X5.04	Relay switching cables
5	AGND_0	Analog GND

Table 17: Pin assignment STC5

STC3

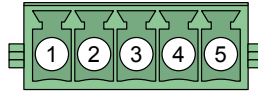

Figure 34: Würth 691305130005

Pin	Designation	Description
1	ST390023 (MIC+)	Cables to the DUT
2	ST390024 (MIC-)	Cables to the DUT
3	ST390029 (SP-)	Cables to the DUT
4	ST390030 (SP+)	Cables to the DUT
5	X3.05	Cables to the DUT

Table 18: Pin assignment STC3

STC2

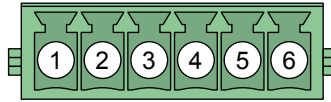

Figure 35: Würth 691305130005

Pin	Designation	Description
1	ST129001 (CELLULAR MAIN1)	Cables to the DUT
2	ST129002 (GNSS)	Cables to the DUT
3	ST129003 (WIFI)	Cables to the DUT
4	ST129004 (CELLULAR MAIN2)	Cables to the DUT
5	UBAT_OUT_0	Cables to the DUT
6	AGND_0	Analog GND

Table 19: Pin assignment STC2

STC1

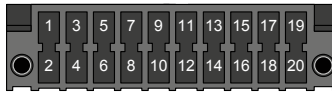

Figure 36: 20-pin Phoenix connector

Pin	Designation	Description
1	ST3900.2 (OPEN)	Cables to the DUT
2	ST3900.3 (OPEN)	Cables to the DUT
3	ST3900.4 (IG2)	Cables to the DUT
4	ST3900.5 (SLPD)	Cables to the DUT
5	ST3900.8 (SIG1 -> SWITCHBOX)	Cables to the DUT
6	ST3900.9 (SIG -> SWITCHBOX GND)	Cables to the DUT
7	ST3900.11 (MIC_GND)	Cables to the DUT
8	ST3900.12 (MIC_PWR)	Cables to the DUT
9	ST3900.13 (TTP6 -> 0R_TO_GND)	Cables to the DUT
10	ST3900.14 (IND1 -> LED RED)	Cables to the DUT
11	ST3900.15 (IND2 -> LED BACK)	Cables to the DUT
12	ST3900.16 (MUTE)	Cables to the DUT
13	ST3900.19 (GSW -> AIRBAG)	Cables to the DUT
14	ST3900.22 (GND -> 0R_TO_GND)	Cables to the DUT
15	ST3900.28 (PPS)	Cables to the DUT
16	X1.16	Cables to the DUT
17	X1.17	Cables to the DUT
18	X1.18	Cables to the DUT
19	UBAT_OUT_0	Cables to the DUT
20	AGND_0	Analog GND

Table 20: Pin assignment STC1

7. Specifications ADQ-CDI-TCU/1

Conditions: TA = 25°C unless otherwise specified; warm-up time: 30 minutes.

Overall

Element	Condition	Specification
Control and signal processing	recommended	ADQ-CDI-TCU/1 for analog input/output, as well as control via I2C- and I2S-Bus/Beagle Bone Black
Supply		Supply via ADQ-CDI-BB
Temperature range	Operating	0..60 °C (Standard)
Air humidity	Operating	20%..55% (non-condensing)
Dimensions (W x D x H)	ADQ-CDI-TCU/Full	235 x 75 x 30 mm Clip-on HAT
Manufacturer warranty		36 months

Diff. analog inputs/outputs ADQ-CDI-TCU/1

Element	Condition	Specification
Channels	Input	4 AC differential inputs 10V peak
Channels	Output	2 AC differential outputs 0.846V peak
Range	CODEC	50 Hz to 20 KHz (see TLV320AIC3204 data sheet)
Sampling rate	CODEC	48 KHz/96 KHz/192 KHz (see TLV320AIC3204 data sheet)
Resolution	CODEC	16 bit (see TLV320AIC3204 data sheet)
Overall accuracy	±10V	0,1%FS
Input impedance	1kHz Sinus	10K
Input capacity		470nF ₁

(1) Reactance XC (frequency-dependent)

Internal Voltage Channels (VBUS)

Element	Condition	Specification
Channels		2 single-ended
ADC Full Scale Range (FS)		40,96V
Measurement Input Range	Single Range	0..15V
Resolution		LSB: 1,25mV
Overall accuracy	0V-10,24V	±0,0035%FS (1,43mV)**
	0V-5,12V	±0,003%FS (1,25mV)**
	0V-5,12V	±0,00175%FS (0,716mV)***
Input Impedance		830K

*While the input range is 15V, the full-scale range of the ADC scaling is 40.96V.

High Speed Measurement, *High Accuracy Mode

Internal Voltage Channel (VDIF) differential analoge Eingänge

Element	Condition	Specification
Channel		1 differential analoge Input
ADC Full Scale Range (FS)		40,96V
Measurement Input Range	Single Range	±20,48V
Resolution		LSB: 1,25mV
Overall accuracy	±20,48V	±1,5%FS (62mV)**
	±10,24V	±0,03%FS (12,2mV)**
	±5,12V	±0,03%FS (12,2mV)**
Input Impedance		3MΩ 100pF

**High Speed Measurement

Small signal relay for ADQ-CDI-TCU/1

Element	Condition	Specification
Type		FTR-B3CA()Z Standard
Quantity		Up to 4 relays optional
Contact type		2-pin changeover contact (DPDT)
Contact material		Silver/nickel with gold plating
Contact resistance	1 A/6VDC	max. 75 m Ω at 1 A/6 VDC
Switching time	Response time	max. 3 ms
	Fallback time	max. 3 ms
Switching cycles	mechanical	min. 50.000.000

Note: Please note the max. switching currents for the auxiliary relays on the STC4 and STC5 connectors.

8. Specifications ADQ-CDI-TCU/1 LC

Conditions: TA = 25°C unless otherwise specified; warm-up time: 30 minutes.

Overall

Element	Condition	Specification
Control and signal processing	recommended	ADQ-CDI-TCU/1 LC for analog input/output, as well as control via I2C- and I2S-Bus/Beagle Bone Black
Supply		Supply via ADQ-CDI-BB
Temperature range	Operating	0..60 °C (Standard)
Air humidity	Operating	20%..55% (non-condensing)
Dimensions (W x D x H)	ADQ-CDI-TCU/Full	235 x 75 x 30 mm Clip-on HAT
Manufacturer warranty		36 months

Diff. analog inputs/outputs ADQ-CDI-TCU/1 LC

Element	Condition	Specification
Channels	Input	4 AC differential inputs 10V peak
Channels	Output	2 AC differential outputs 0.846V peak
Range	CODEC	50 Hz to 20 KHz (see TLV320AIC3204 data sheet)
Sampling rate	CODEC	48 KHz/96 KHz/192 KHz (see TLV320AIC3204 data sheet)
Resolution	CODEC	16 bit (see TLV320AIC3204 data sheet)
Overall accuracy	±10V	0,1%FS
Input impedance	1kHz Sinus	10K
Input capacity		470nF ₁

(1) Reactance XC (frequency-dependent)

9. Appendix

9.1 Manufacturer and support

ALLNET® is a registered trademark of ALLNET® GmbH Computersysteme. If you have any questions, problems or require product information of any kind, please contact the manufacturer directly:

ALLNET® GmbH Computersysteme

Division ALLDAQ

Maistrasse 2

D-82110 Germering

E-Mail: support@alldaq.com

Phone: +49 (0)89 894 222 – 474

Fax: +49 (0)89 894 222 – 33

Web: www.alldaq.com

9.2 Important notes

9.2.1 Packaging Ordinance

“In principle, manufacturers and distributors are obliged to ensure that sales packaging is taken back by the end consumer after use and reused or recycled.” (according to § 4 sentence 1 of the Packaging Ordinance). If you as a customer have any problems with the disposal of packaging and shipping materials, please send an email to info@allnet.de.

9.2.2 Recycling notice and RoHS conformity



Please note that parts of ALLNET® GmbH products should be disposed of at recycling centers or may not be disposed of with household waste (circuit boards, power supply unit, etc.).



ALLNET® products are manufactured in compliance with RoHS (Restriction of the use of certain hazardous substances).

9.2.3 CE marking

The ADQ-CDI-BB bears the CE marking.



This device complies with the requirements of EU Directive 2004/108/EC, Electromagnetic Compatibility Directive and the mutual recognition of their conformity. Conformity with the above directive is confirmed by the CE mark on the device.

9.2.4 Guarantee

Within the warranty period, we will rectify manufacturing and material defects free of charge. You can find the warranty conditions valid for your country on the homepage of your distributor. If you have any questions or problems with the application, you can reach us during our normal opening hours at the following telephone number +49 (0)89 894 222 - 474 or by e-mail at support@alldaq.com.



ALLNET® GmbH Computersysteme
Division ALLDAQ
Maistrasse 2
D-82110 Germering
E-Mail: support@alldaq.com
Phone: +49 (0)89 894 222 – 474
Fax: +49 (0)89 894 222 – 33
Internet: www.alldaq.com

